

- ✓ Introduction
- ✓ Technical Specifications
- ✓ Prepare
- ✓ Installation
- ✓ Operation
- ✓ Maintenance
- ✓ Film Defects
- ✓ Current flow chart
- ✓ Problems and Solutions
- ✓ Spare parts list

Introduction

The Processor is a compact, automatic table-top processor. The Film materials are developed, fixed, rinsed and dried.

The film processor has been fitted with an automatic film-registration and a stand-by mode. The developing solutions are temperature-regulated, circulated and automatically replenished.

The Operation Manual has been fitted with an automatic film-registration for installation, Operation and servicing of this machines. Please regard the given information carefully to ensure a reliable and satisfactory operation of the machine.

Technical Specifications

- ✧ Film sizes: Min. 10×10cms up to 35cms width
- ✧ Process time: 105/135/165 secs
- ✧ Linear Speed: Adjustable 550-140mm/min
- ✧ Developer time: 28/36/44secs
- ✧ Tank Volumes: each 5.2 LITRES
- ✧ Replenishment: Automatic replenishment by film detection adjustable 200ml/m²
- ✧ Developer temperature: Adjustable 28-37°C
- ✧ Fixer Temperature: Adjustable to developer temperature by heat exchanger
- ✧ Dryer temperature: Adjustable 65°C
- ✧ Water temperature: 5°C-30°C
- ✧ Water consumption: 2 litres/min. during processing
- ✧ Power Source: 220V 8.8A 50HZ
- ✧ Weight: 50kgs(empty)
55kgs(filled)
- ✧ Dimensions(L×W×H):77×59×42cms

Perpare

1 Fresh water connection:

Stop cock with 3/4" outer-thread diameter(washing machine connection).Water pressure should be between 2-10bar.

2.Drainage connection:

Plastic hose-inner-diameter 50mm or larger.A ventilated siphon which serves as odour preventor should be included in the planning.The drainage hose should be installed with a fall of minimum 5%.To avoid blockage ensure.that the drainage hose is kink free.

Local Water Authorities regulations should be complied with!

3.Electrical connections:

Fused socket with earth connection,220V, 50Hz,8.8A should be used.An intermediary socket and power connection with control and F-switch with 25A/30mA nominal error-current are recommended.

Electrical connections should be carried out according regulations by an electrician.

Installation

1. Unpack the processor.Remove cover and transport securing brackets on the sides of the roller racks.Remove roller racks-start with the dryer rack.
2. In the event that the processor is to be installed on the support stand.the base table feet are individually adjustable in height.
Attention:Machine must be installed on the support stand which our provided. if the ventilation openings under the machine cause blockage,the machine will overheating
3. Install the processor on the support stand and level out horizontally.To do this place spirit level across the sides of processor and adjust the feet accordingly.
4. Connect the enclosed hoses to machine.This is easy to do when the hose ends are slightly heated and then pushed over the respective connection.The hose piping should be without kinks and with a constant fall.

Pay attention to the correct colour connections:

Developer:blue Fixer:yellow Water:green

Installation

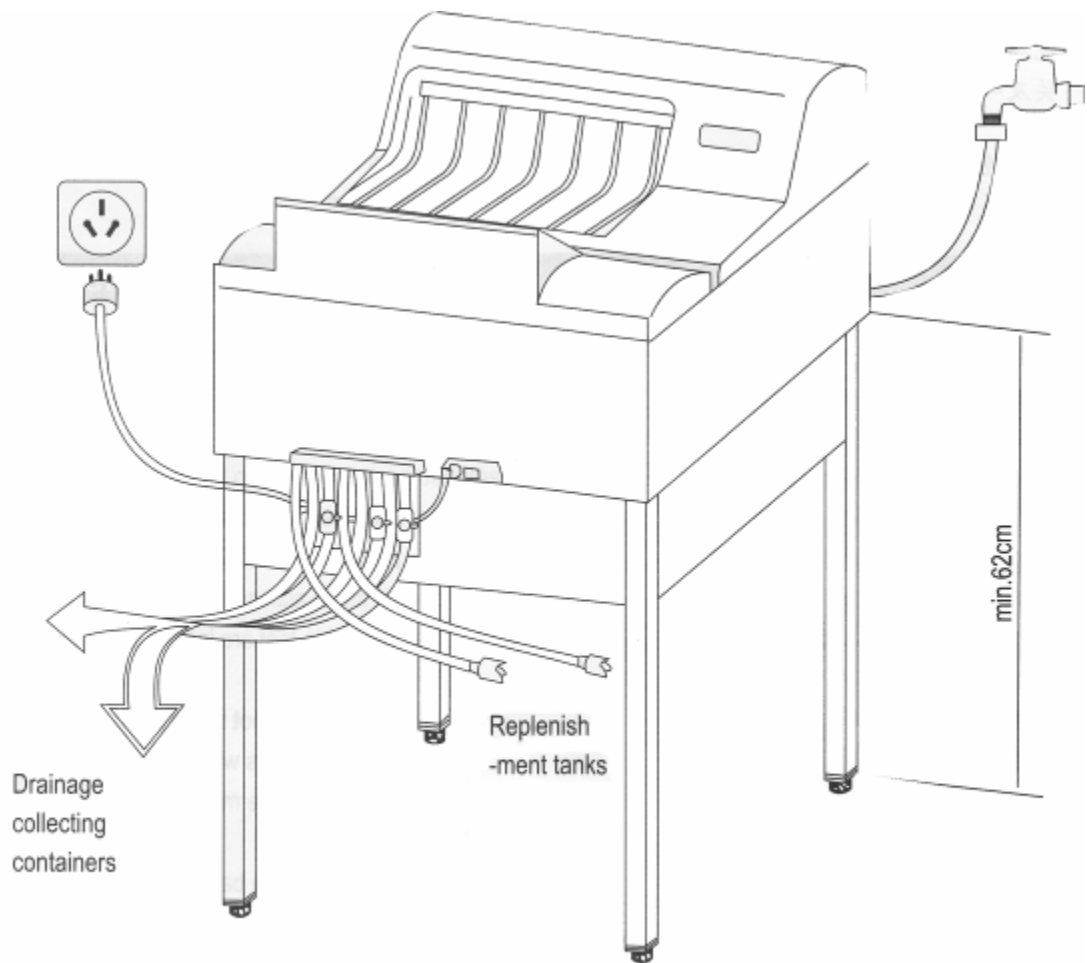

As an option a processor stand is available.

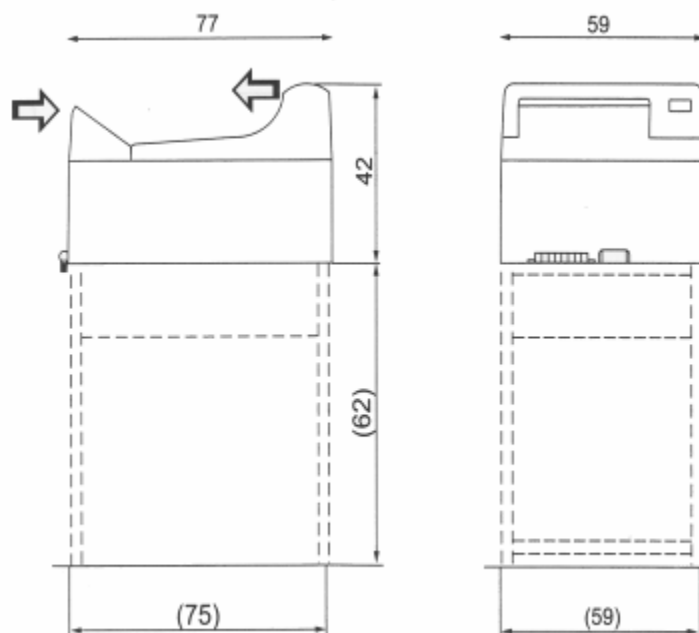

Installation Plan

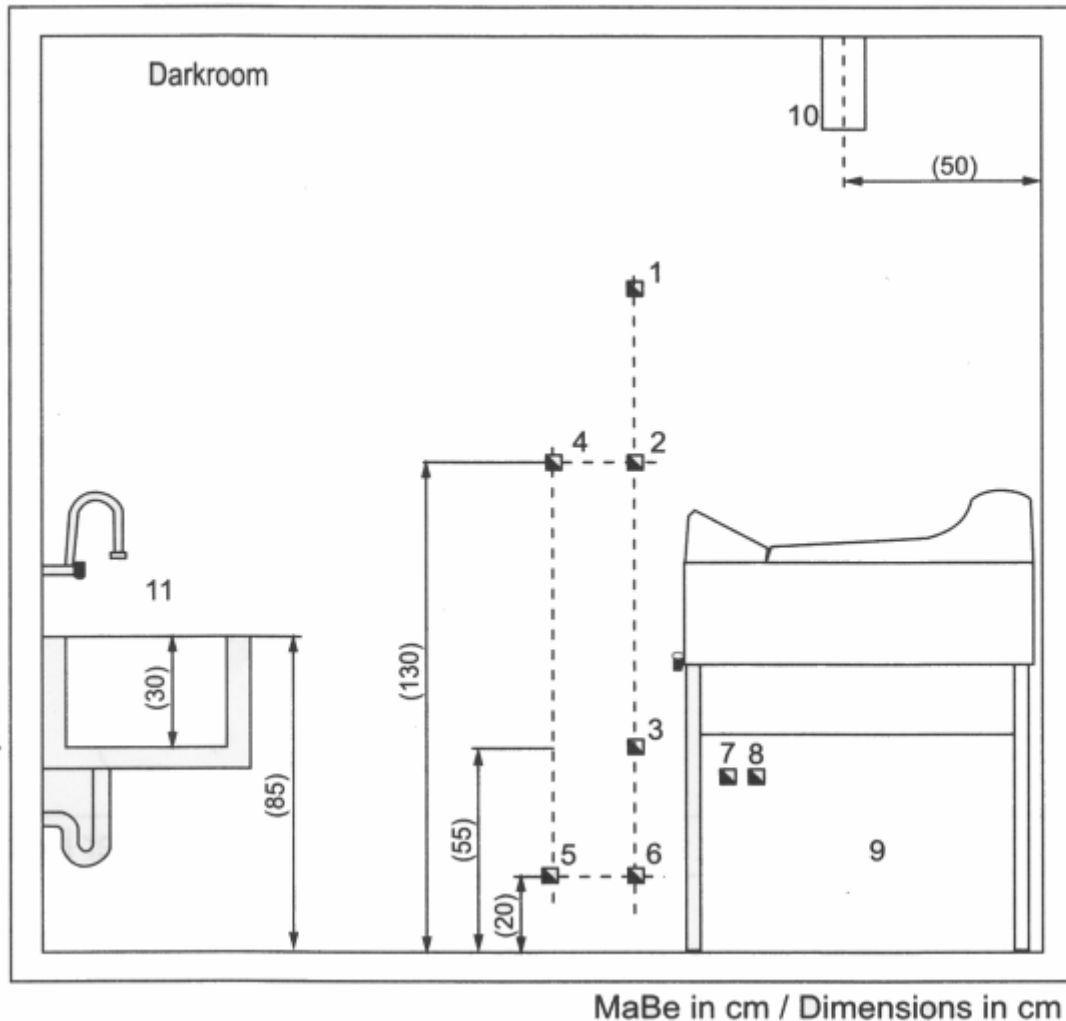

- 1 Power source 220V,16A($3 \times 1.5\text{mm}^2\text{Cu}$)
- 2 5A/30mA nominal error-current.
- 3 Control-switch 16A
- 4 Fused socket(16A)with earth connection.
- 5 stop cock for water supply.
- 6 Fresh water connection with 3/4" outerthread diameter,2-10bar,5-30
- 7 Drainage,collecting containers of developer
- 8 Drainage,collecting containers of developer
- 9 Storing space for replenishment tanks:Under machine or externally
- 10 Ventilation of darkroom is necessary
- 11 Sink with freshwater and flexible hose.Inner dimensions $60 \times 40 \times 30(\text{L} \times \text{W} \times \text{H})$

Installation

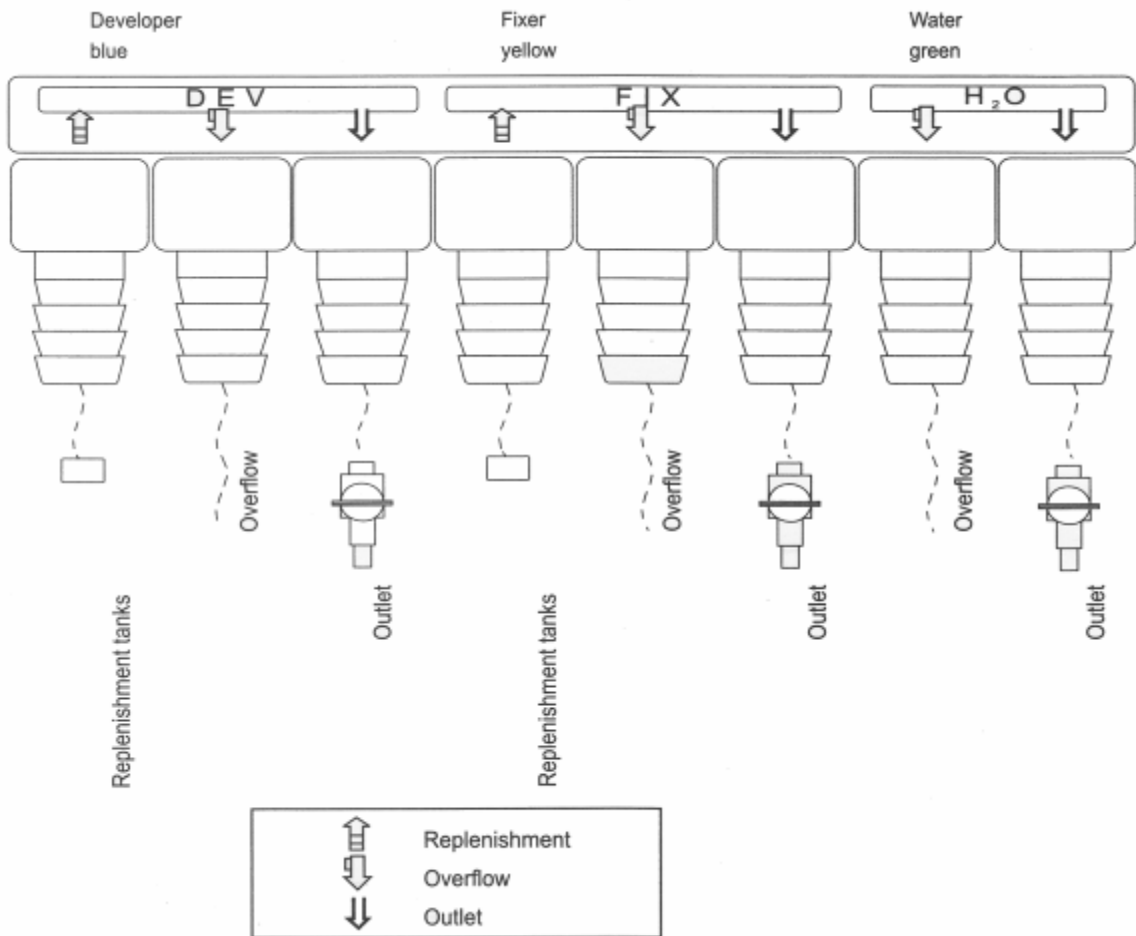

The stop clicks on the three drainage hoses should be installed in such a position, that they are easy to reach at all times, The overflow hoses for the developer and fixer should be guided into the respective collection containers. The overflow and drainage hoses of the water can be guided into the drainage siphon. To secure the hoses, the cable binders (accessory bag) can be used.

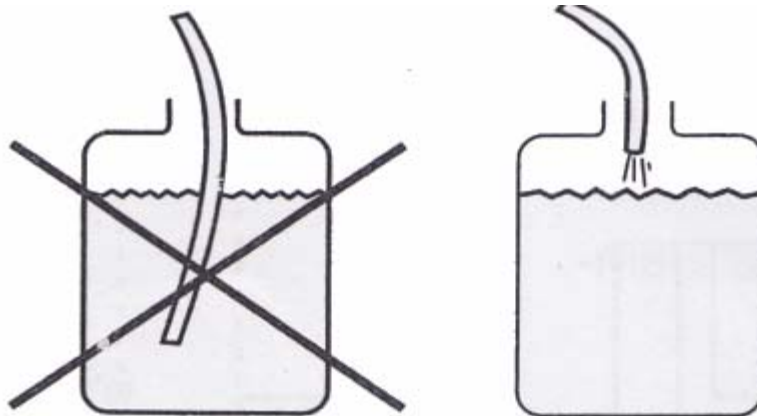

The local Water Board regulations regarding drainage should be complied with!

Test run

Important: Processor should not be run dry!

- a) Close the three drainage stop cocks and fill the tanks and replenishment containers with water. Open water inflow tap. connect electrical socket and switch the machine on. Water now flows into water tank. The circulation pump activates, however the hosing of the machine must be ventilated
- b) Ventilation of the replenisher pump:
Press the switch in the infeed tray and keep pressed. The replenisher pump is activated. Keep the switch pressed until no more air bubbles appear in the tanks. (or Press Replenisher Key)
- c) Ventilation of the circulation pump:
If air is in the circulation pump, a loud running noise can be heard. Switch the machine off again. Open the stop cocks of the developer and fixer for 5 seconds and switch machine on again. Repeat this procedure until no more air bubbles are visible in the developer and fixer baths and until the circulation pump runs quietly. Check all hose connections for leakage. Switch machine off and drain water out.

Fill processor with chemicals

The chemicals should be prepared according to manufacturers instructions. By using a suitable container, pour chemicals into the respective tanks. First The fixer and then the developer. Caution: when filling, be sure that chemicals do not splash from one bath into another. When fixer solution is mixed with developer solution, the developer chemical is destroyed.

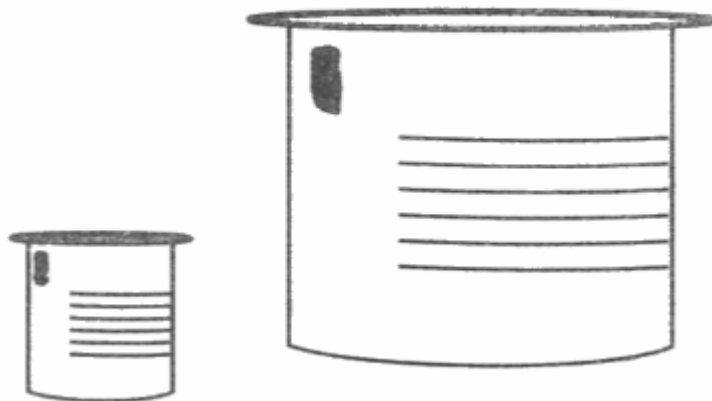

Operation

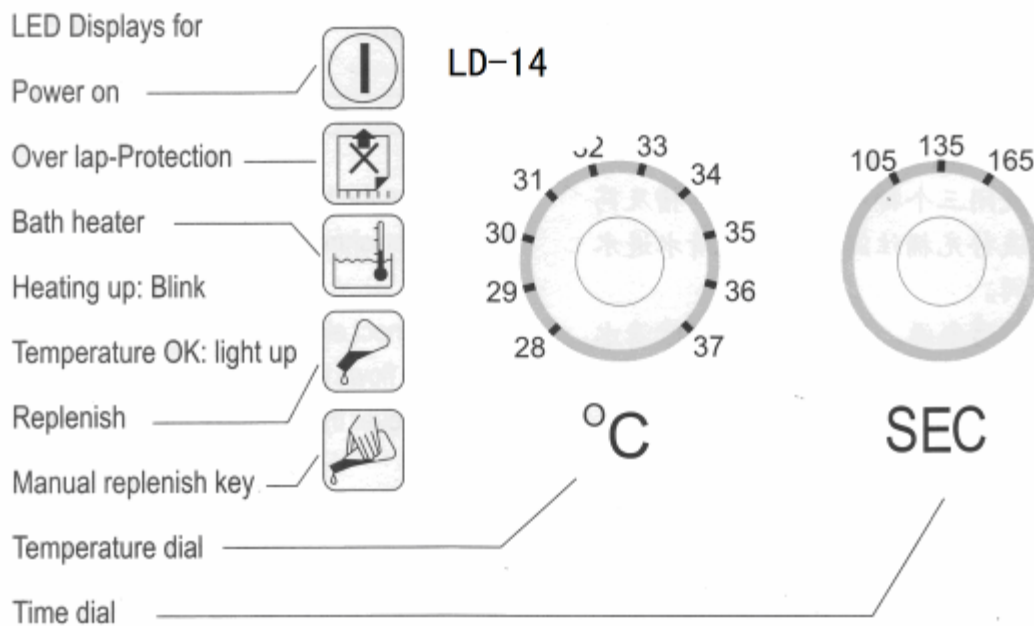

- ① Before switching the machine on, close the water drainage stop cock and open the freshwater tap. When working has finished for the day, it is essential that the freshwater tap is turned off again and by opening the water-drainage stop cock the water drained out of the machine.
- ② Switch the machine on. The water tank fills and the ventilator fan feeds fresh air in. The developer and fixer baths heat up. When the required temperature is reached, the LED bath heater blinks.
- ③ Open light protection cover. Place film on left side of feed tray and feed in.
- ④ The film switch starts the transport and the replenishment.
- ⑤ The Overlapping safety device LED lights up.
- ⑥ The film is developed.
- ⑦ fixed
- ⑧ in the water bath
- ⑨ the film is rinsed and dried.
- ⑩ the processed film leaves the machine.

Stand-by mode:

When no film is being processed, the machine switches on to stand-by. The chemicals remain at a constant temperature. The film transport and water inflow activate at intervals to avoid crystallisation of the chemicals on the transport rollers. Entry of the next film is possible at any time.

Operation

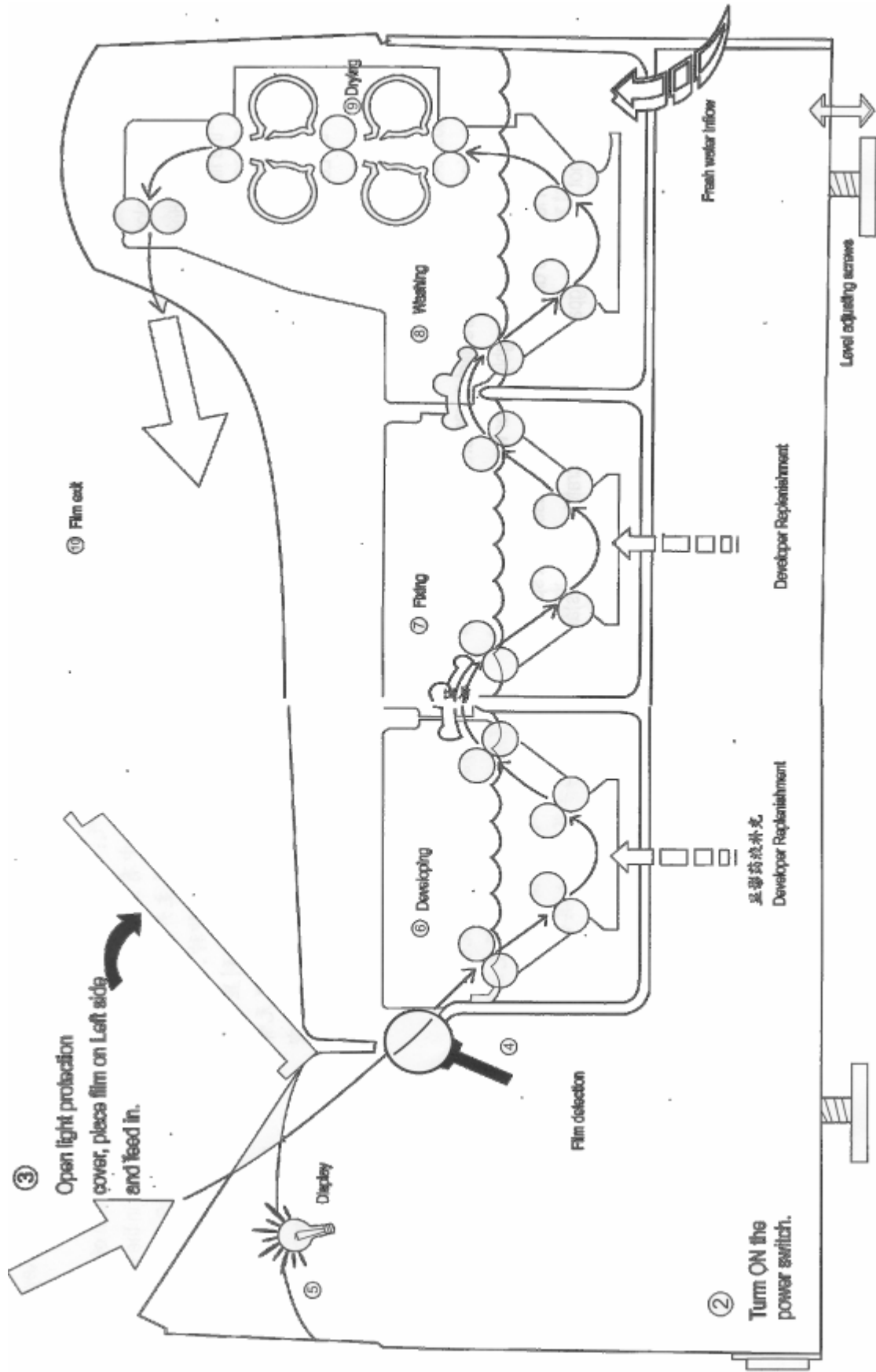

Daily Care



① Before switching on, close water drainage stop cock and open water tap! Turn up the in-pour water.

When work has finished for the day, remember to turn water tap off again and drain water out of the machine.

② Turn on the power switch

③ Open light protection cover, place film on left side and feed in.

When close the power switch, you must turn on the top cover.

Attention: After lead in film if you change the drive. The last film will not exit from the drying.

Before use.....

- Remove dirt and dust from film-feed soft cloth.
- Run 2-3 cleaner films through processor to remove all accumulated dirt and dust from the rollers.
- Check the liquid level in the replenishment containers and if necessary refill.
- Leave light protection cover open when no film is in the processor. This avoids condensation on in-feed.

After use.....

- When working has been completed at the end of the day, drain water out of the machine. This avoids the growth of algae in the water.

After A Week

The developer chemicals cause residue build-up in the machine. This residue has a negative effect on the developing process of the film material. For this reason the processor should be regularly freed of this residue.

- a) Switch machine off and remove cover.
- b) Loosen the securing latches the drive shafts of each roller rack at the right side.
- c) Remove the roller-racks. First of all remove the large dryer-rack (natural-co-Our). The racks are easier to remove and insert when these are slightly tilted.
- d) Rinse all racks thoroughly under warm running water and then leave to drain off. It is advisable to use a soft sponge (do not use scouring pad, as this would scratch the rollers) and remove the pollution from the rollers.
- e) Replace the racks. Ensure that the racks are firmly installed and do not forget to close the securing latches on the drive shafts.
- f) Clean processor outer casing with damp cloth. Do not use aggressive cleaners or solvents.

After Three Months

Depending on the quantity of processed films, a thorough cleaning is necessary every 3 months. Tank cleaners are available for developer and water Baths. The fixer bath can be cleaned with water. When preparing chemical tank cleaners, follow manufacturers instructions explicitly.

How to processed:

- a) Switch the machine off and empty all tanks by opening the stop cocks.
- b) Remove the machine cover. When all tanks are emptied, then close stop cocks again. Now fill the fixer-tank with water. Prepare cleaner solutions for developer and water baths and fill into the respective tanks
- c) Remove the suction pipes from the replenisher containers and place them in water filled containers or buckets.

Attention: Don't add chemical cleaners here!

- d) Close machine cover and switch machine on.

After Three Months

- e) Start processor by placing film in infeed that film detector switch is pressed down and film is not been pulled in.
- f) Keep the machine running for 10 to 20 minutes. During this procedure, the installed roller racks will be cleaned.
- g) Important: After completion of tank cleaning, these should be rinsed thoroughly with clean water –to do this, fill the machine with fresh water twice and each time, let the machine run for 10 minute periods. This is necessary to ensure that all tank cleaning chemicals are removed. Then remove roller-racks and rinse them thoroughly with water in a sink. Empty the tanks and reclose the stop cocks.
- h) Refill the tanks with respective chemicals and replace the suction pipes into the replenisher containers. if necessary ventilate the circulation pump.
- i) If this is your first time in cleaning tanks, and you want to check if everything is ok, then you should run test films through the machine.

Before you go on holiday.....

Or you don't need to use the machine for longer than two weeks, the chemicals must be emptied out of the tanks. if you don't want to do a complete tank-cleaning then least you should fill the tanks with water.

Current flow chart

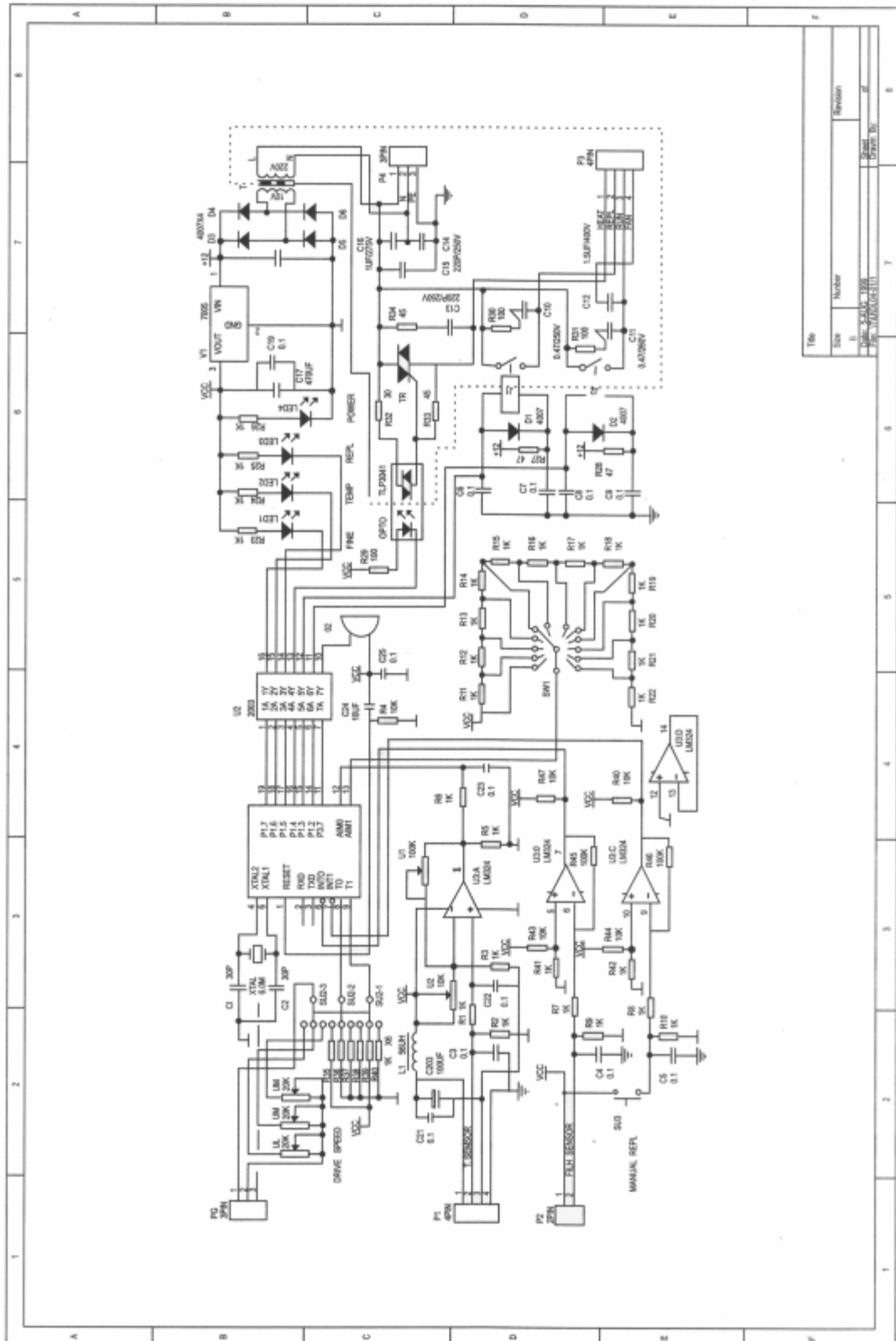

Current flow chart

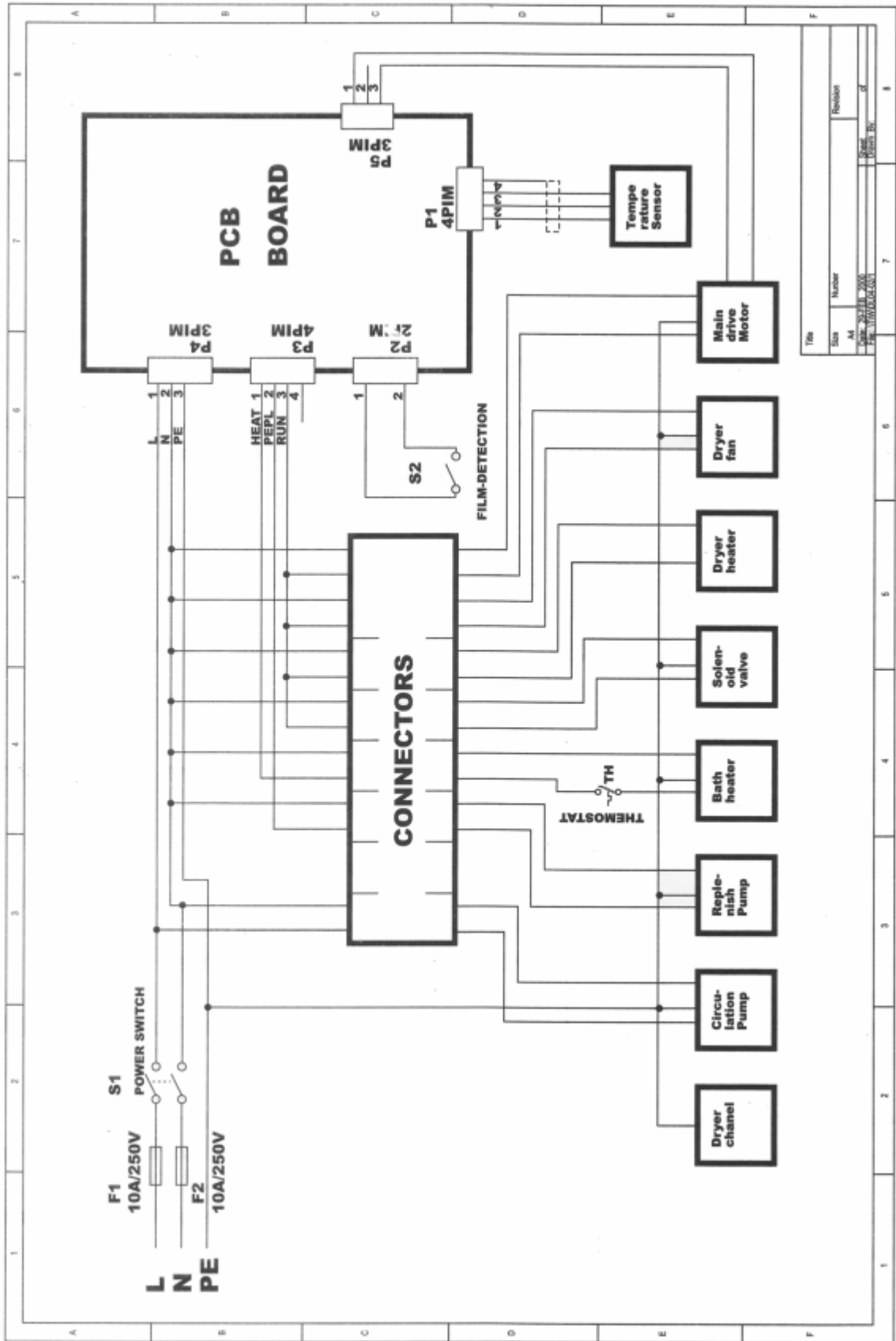

Problems and solutions

Your processor has been constructed for intensive and long term use. if however irregularities should occur, you will find help to locate the problem below. please check the listed points, before calling your service-technician.

Film do not have enough density

- Bath temperature is too low.
- Exposure time is too short.
- Developer chemicals are exhausted:renew.
- Fixer solution has been mixed into developer solution:Renew make sure that the bath has been cleaned and rinsed well before refilling.

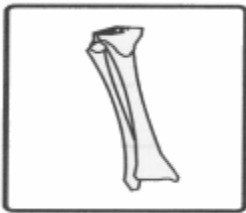

Too high a density

- Bath temperature is too high.
- Exposure time is too long.
- After renewing chemicals,starter is missing.



Films will not dry

- When warm air comes out of air channel,chemicals and film type should be checked.
- Fixer solution is exhausted or diluted.

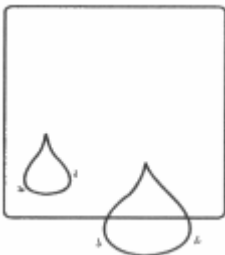

Problems and solutions

Film material has a yellow-green surface

- Not correctly fixed. Check the film type.
- Fixer solution is exhausted or diluted replenishment rate of fixer is too low.



Scratches, pressure marks, dirt on film

- Prior to starting work with the processor, run cleaner film through
- Pressure marks caused by careless handling, finger nails etc.
- Rollers are polluted. Clean tanks and roller racks.

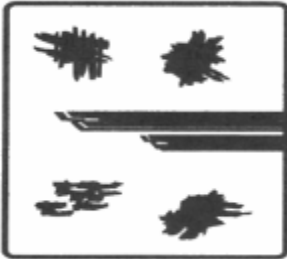

Machine without voltage

- Ensure that electrical socket has power supply.
- Check machine fuse in master switch.
- While power switch is on, check the following components:
 - Voltage on plug-if no voltage-change plug.
 - Check voltage at electronics connections if the voltage is normal, exchange the electronics. if no voltage can be registered, check the cable wiring harness.

Filmfeed out of order, dryer-fan is working

- Check chain gear screws on motor-and driveshaft.

Machine does not start automatically

- Film-detection switch is not correctly positioned. Operator wire is bent.
- Check film-detection connections. film-detections switch or electronics are defect-replace.

Machine doesn't stop automatically, motor and ventilator run continuously

- Overlapping protection LED is permanently illuminated: Wire band of film detection is jammed. Readjust wire.
- Electronic is defect-replace.

Problems and solutions

Rinsing water does not flow

- Water pressure in the water system is too low:Minimum pressure 2bar.
- Valve activates,no flow passage-filter at inflow is blocked.

Water tank overflows

- The cupour water tas much.
Water drainage tube(overflow)should have a constant fall.The tube end should be positioned above the drainage level in the siphon.
- Check water drainage in the tank and tube for blockage and pollution.
- When extreme algae growth is registered,the overflow can be connected directly onto the fitting of the water tank.

Developer temperature too high

- Check temperature feeler.The feeler should be firmly positioned on tube and completely be covered with foam rubber.
- Electronis defect-exchange.

Developer temperature too low

- Air in the circulation pump:Ventilate pump
- No circulation:Circulation pump has no power supply or is defect.
- Temperature limiter of the heat-exchanger is defect.
- Check heating element:current flow resistance should read approx.60 Ω
- Check temperature feeler.
- Electronics detect-exchange

Fine tuning of developer temperature(pic.2)

- Deviating temperatures can be fine tuned by a potentionmeter on the printed circuit board.it can be reached after demounting the turning knob from above.Turning clockwise increases the temperature.

Demounting of the turning knob(pic.1)

- 1 Open the cover of the knob by help of the screwdriver.
- 2 Turning clockwise and pull the knob out.

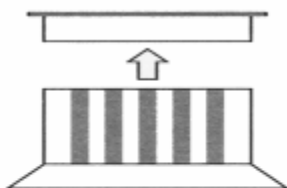

Pic.1

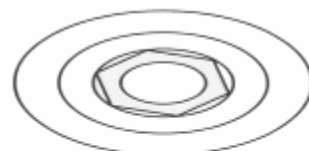

Pic.2

Problems and solutions

Films will not dry

- No air comes out of air channel:the ventilator is defect and should be exchanged.
- Cold air comes out of air channel,the heating element in the air channel is defect,exchanged.
- Hot air comes out of air channel,but the film is still not dried to satisfaction.if atrer checking the chemicals and film type,no reason can be found,then the speed of the machine can be reduced.

Ventilation does not fuction of fan runs half power

- Check the correct connecting of the ventilation cables.
- If the connecting wires of the fan are wrongly connected,then the condenser motor runs only half power,this can be recognized by the glowing of the heating element.

Replenisher pump does not pump

- Clean valves on the connecting pieces
- Replenisher tube sucks air in.Check the connections.
- Check excenter positioning.Transport quantity reads 119ml/min at maximum adjustment.

Replenishment rates are too high or too low

- The replenishment rate can be altered by adjusting the stroke of the pump.to do this the excenter on the replenisher pump must be adjusted.Max.pumprate 119ml/min.

The film does not transport correctly

- Check the positioning of the racks in the machine and make sure that the latches are closed.Check the gears on the roller racks,the position of the guide elements and the roller pressure.
- Motor runs:The worm gear of the drive shaft should be secured with a splint to avoid twisting.Check the screws and positioning of the gear chain.

Motor does not run

- Motor has voltage:Exchange motor.
- Ventilator runs but no voltage on motor:interruption in the current flow

Scratches,pressure marks,dirt on film

- Straight scratches in the infeed direction indicate faulty guide elements.Check each rack and straighten up the guide element.if mechanically damaged,replace the guide elements.

Problems and solutions

- Pressure marks caused due to polluted or damaged rollers: Exchange rollers.

No circulation in bath

- Circulation pump does not function, no circulation: Air in heating and circulation system. Dirt in the pump chamber.
- Pollution in the pump chamber. The pump chamber can be easily opened by removing the six clips. When reclosing ensure that the rubber seal is
- positioned correctly and not damaged.

Spare parts list

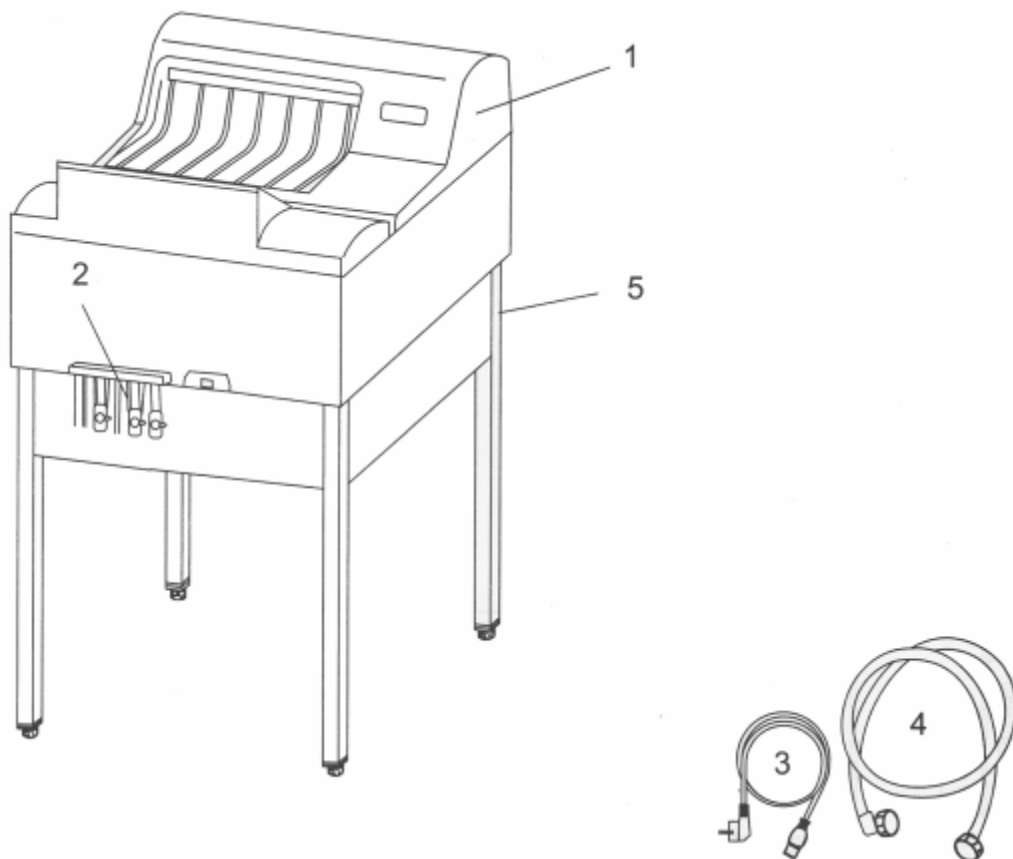

1	00101
2	00102
3	20101
4	10101
5	00201

complete cover
Drain stop cock 10mm
electrical power lead
water inlet tube
processor stand

Spare parts list

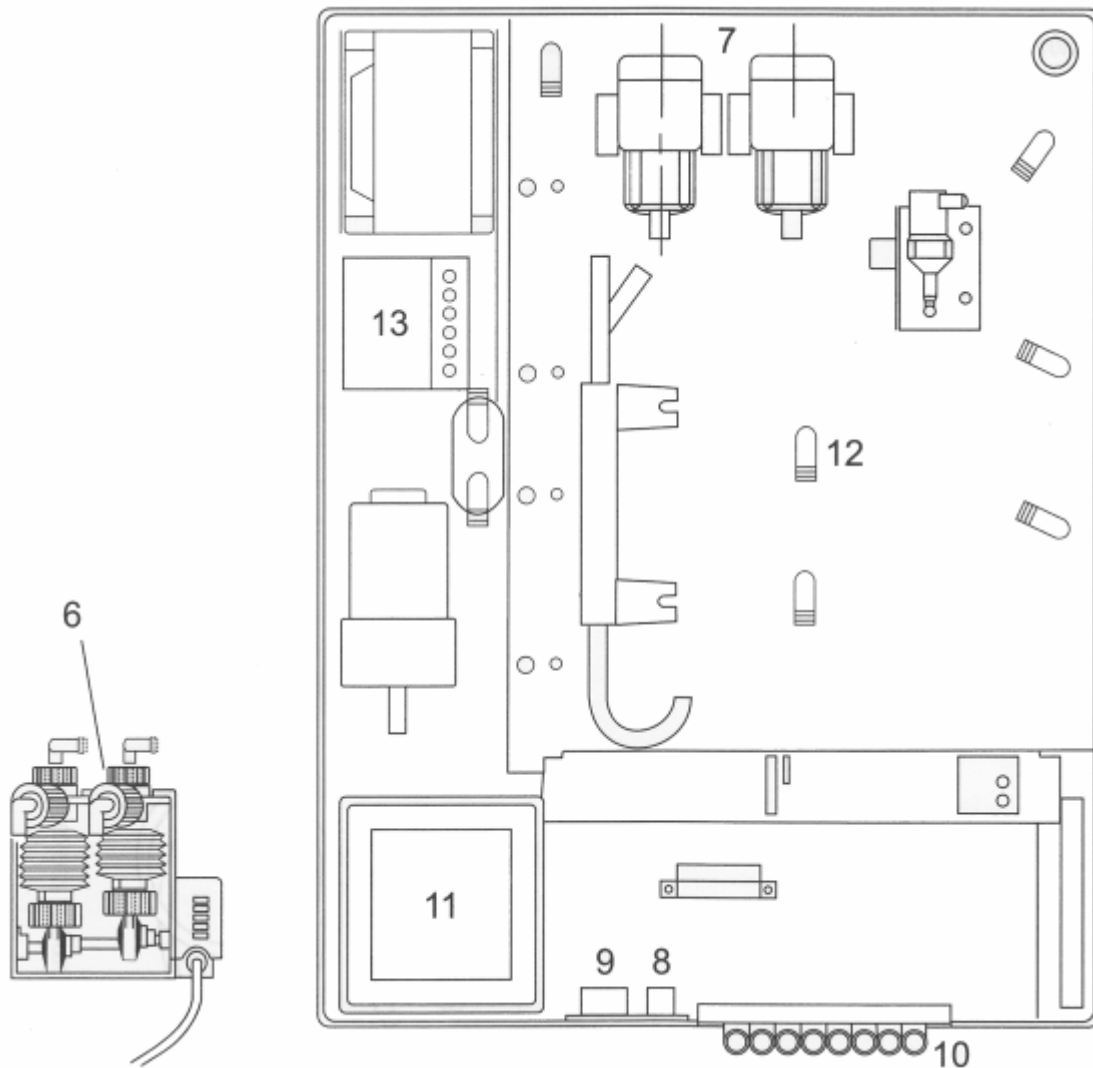

Term	Description
------	-------------

6	replenisher pump
7	circulation pump
8	main switch combination
9	fuse slow blow10A/250V
10	angle connection(grey)
11	electronic
12	angle fitting
13	driver comtrel

Spare parts list

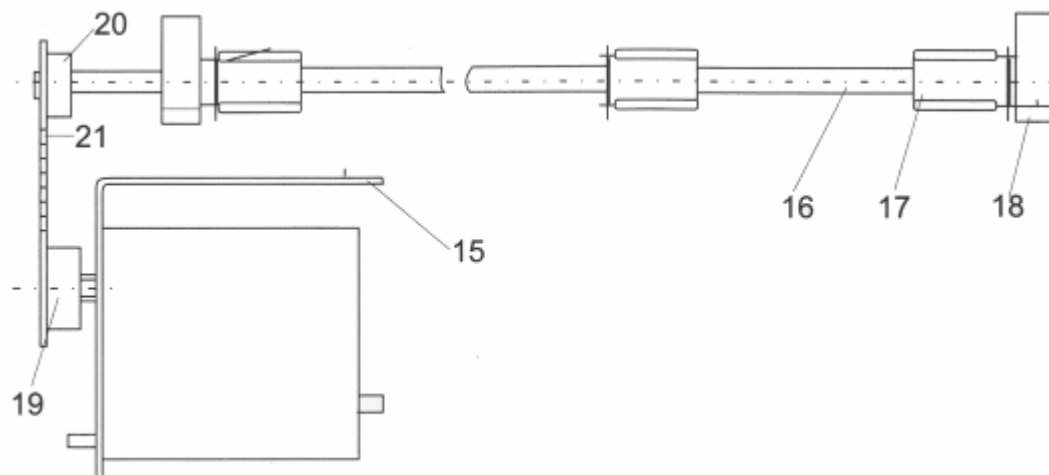

Term	Description
14	main drive motor
15	motor bracket
16	drive shaft worm-gear
17	worm wheel
18	bearing block
19	chain wheel on motor t=17
20	chain wheel on drive shaft t=17
21	Link

Spare parts list

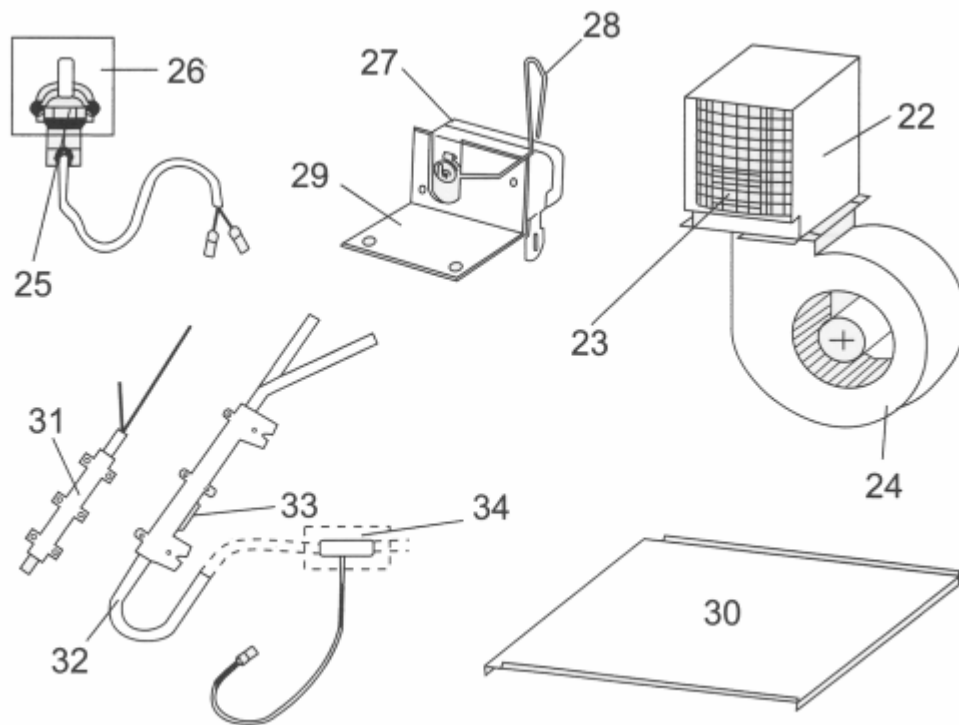

Term	Description
22	air channel
23	heating element 220V 1000W
24	dryer fan 220V,50Hz
25	solenoid valve 220V,60Hz
26	securing bracket
27	micro-rotary-switch f.film-detection
28	operator f.micro-rotary-switch
29	bracket f.micro-rotary-switch
30	film feed tray
31	heating element 220V 500W
32	heat exchanger
33	overtemperature regulator mounted on heat exchanger
34	temperature sensor

Spare parts list

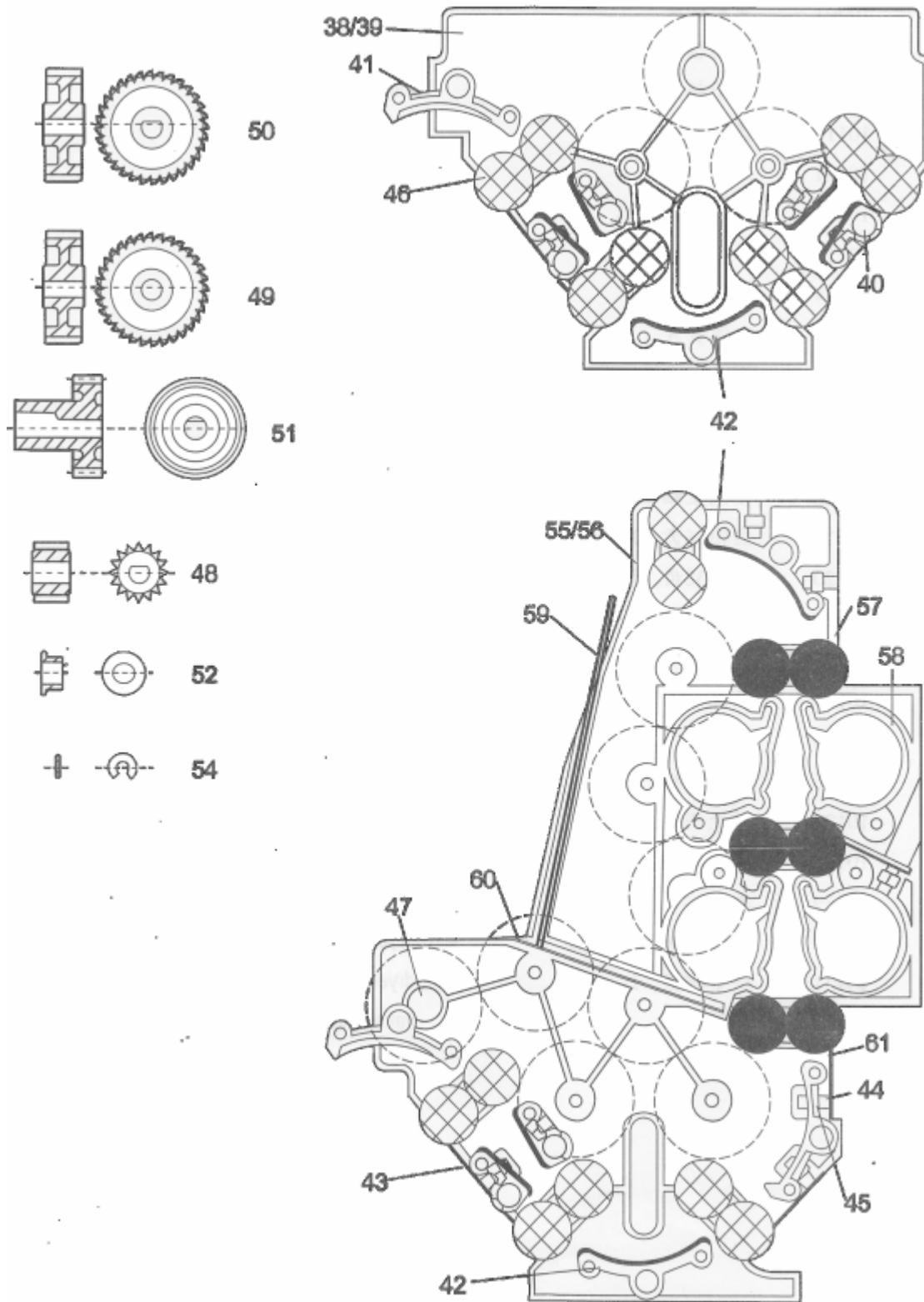

Spare parts list

Term	Description
35	roller rack developer
36	roller rack fixer
37	roller rack dryer
38	side plate dev
39	side plate fix
40	guide bar short
41	guide bar with nose
42	guide bar,bent
43	flat spring 56
44	screw M4X10,Inox
45	nut M4,inox
46	PU-roller ground
47	drive shaft rack
48	gear t=16 D-hole
49	gear t=32 round-hole
50	gear t-32 D-hole
51	tooth gear
52	bearing bush
53	circlip
54	dryer side plate left
55	dryer side plate right
56	rubber roller
57	air jet
58	dryer plate large
59	dryer plate small
60	flat spring 36